

## Warning

*Propane gas is highly flammable and under pressure in the cylinder. Do Not store or use gasoline or other flammable liquids or vapors in the vicinity of this lantern. If you detect the odor of gas, immediately evacuate the enclosed area and contact the appropriate authorities/professionals.*

.....

*Please read carefully to ensure your safety:*

- 1) Read and follow all instructions.
- 2) When used in an enclosed area, allow for ample ventilation.
- 3) Do not expose the propane cylinder to excessive heat.
- 4) Always inspect the lantern, propane cylinder and connectors for damage, debris or dirt before attaching the cylinder to the lantern.
- 5) Always attach/detach the propane cylinder away from any open flame or pilot light and only after the lantern has cooled.
- 6) Do not use or operate if either the lantern or propane cylinder is found to be damaged.
- 7) Always disconnect the propane cylinder when not in use and/or transporting. Store in an upright position and in a cool, well ventilated area.
- 8) Be sure to tightly secure all connections to the propane cylinder prior to usage.
- 9) Absolutely never operate the lantern near any flammable liquids or vapors and keep all flammable or combustible materials beyond the clearance zone as indicated on the back panel.
- 10) Discontinue operation and close valve if:
  - Ambient temperature drops below-10°F.
  - There is no fuel remaining in the propane cylinder.
  - Lighting cannot be performed quickly and easily.

- Combustion becomes unstable or there are repeated flame-outs.

- 11) Should a blockage occur in the fuel jet, do not attempt to clear it with a metal object. Remove the jet, soak in mineral spirits and then clean and dry to remove any trace of mineral spirits. A short burst of fuel can be used to confirm that the blockage has been cleared.
- 12) Absolutely do not use as a space heater, for cooking, or in a tent.
- 13) Always use the lantern in an upright position.
- 14) Always use the bail handle when moving the lantern. Note that the bail handle should always be returned to its down position after lighting or moving. If the bail handle is left in its up position (i.e. when the lantern is hung via the bail handle), the bail handle will be hot and should not be handled for at least 15 minutes.
- 15) Keep out of the reach of children.

**✍ CONNECTING THE FUEL CYLINDER:**  
*Use only 16.4 oz. propane cylinder as approved by the United States Department of Transportation.*

- 1) Make sure the valve knob is turned off (twist in a clockwise direction).
- 2) Make sure the rubber seal is clean, undamaged and in its proper centered position. The rubber seal is part of the valve adapter assembly and the cylinder connection is to be made to the underside of the lantern adapter assembly.
- 3) Screw the propane gas cylinder onto the lantern valve adapter. Hand tighten only.
- 4) Apply soapy water to the connection to check for leakage. (Leaking gas will form bubbles).
- 5) After determining there is no leakage, draw a flame toward the mantle and slowly open valve (twist counter- clockwise) while maintaining as much dis-

tance as possible. Please wait a couple of minutes to move the lantern.

**✍ INSTALLING NEW MANTLES:**

- 1) Remove bail handle, hood and glass globe.
- 2) Remove all traces of the old mantle.
- 3) Follow “Assembly” steps 4-6.

**✍ ASSEMBLY:**

- 1) Place a propane fuel cylinder into plastic base.
- 2) Attach propane cylinder to valve adapter and assembly (Please refer to steps 1-4 of “Attaching the fuel cylinder”).
- 3) Remove bail handle, lantern hood and glass globe.
- 4) Tie a new mantle in the groove on the burner of the assembly so that the mantle’s flat side is as close to the burner tube as possible without actually making contact.
- 5) Trim any excess string.
- 6) If new, prime the mantle. Note that before priming, check to see if the valve is completely turned off by turning the valve knob clockwise.
- 7) Hold a lighted match to the bottom of the mantle so that it burns evenly. This reduces the mantle in terms of size and causes it to turn a gray/white color. The mantle will burn-off completely in 2-3 minutes. (Note: Do not touch the mantle after it has been lit and avoid handling it after priming).
- 8) Place the glass globe over the burner tube assembly and into the globe frame.
- 9) Place the hood over the entire assembly and align the holes in the hood with those in the globe frame.
- 10) Insert the bail handle through the holes in the hood and globe frame and then screw down the knurled knob on the top of the hood.

Item #170

**FOR YOUR SAFETY:**  
*Do not store or use gasoline or other liquids with flammable vapors in the vicinity of this lantern*

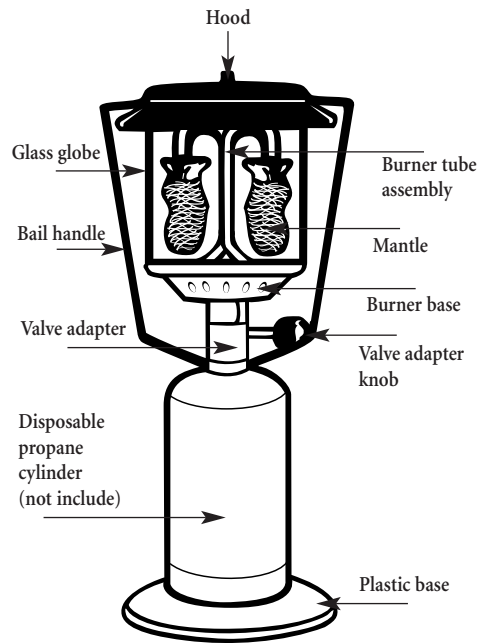

• Propane cylinder not included

**MINIMUM CLEARANCE  
TO FLAMMABLES OR  
COMBUSTIBLES**

Keep lantern away from flammables or combustibles. Never allow fabric, clothing, or any flammable or combustible material to come within the following distances:

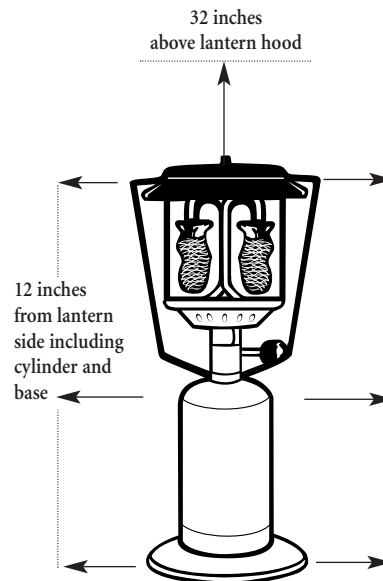

Double Mantle  
**Propane  
Lantern**  
Operation & Maintenance

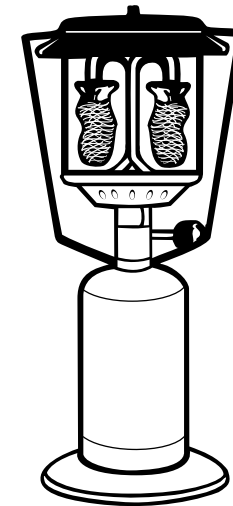

Item #170